

DART ROUND SMALL REMOTE

Compact Professional Adjustable Floodlight

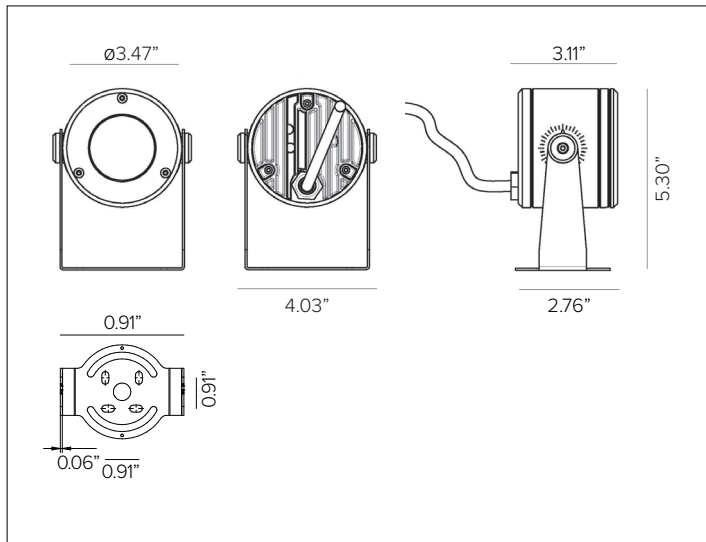

DART ROUND SMALL REMOTE Shown in Ferrite Dark Grey finish.



CONCEPT

Small footprint fully adjustable LED projector with remote driver.

MECHANICAL CHARACTERISTICS

Dimensions	5.30"H x 4.03"W x 3.11"D
Materials	Die-cast aluminum powder coated body and joints for maximum heat dissipation.
Finish	Textured finish. ● Ferrite Dark Grey ● Heritage Brown ● Bronze ● Black ● White ● Sandstone Grey
Power Connection	Pre-cabled with 25' Belden direct burial 18ga 2 conductor cable for connection to remote power supply.
Functionality	Adjustable up to ±60° on the horizontal plane with slotted mounting base and +90°/-45° on the vertical plane with aim locking set screw.
Mounting	Fixture can be installed directly to mounting surface or used with optional mounting installation accessories.
Weight	1.5lbs
Protection	IP66
Impact	IK10

CERTIFICATIONS

cULus Class 2 Wet Location Listed.
 Tested in accordance with LM-79-08.
 Compliant with California energy regulations.
 IEC 62471.
 RoHS3 EU 215/863

WARRANTY

5 year limited warranty

ELECTRICAL CHARACTERISTICS

Power Supply	Remote Class 2 120V-277V AC power supply required, see available options.
Wattage	2W (NSP) / 15W nominal (SP / FL / MWFL)
Voltage	24V DC
Ambient Temp.	-25°C / +35°C (95°F)

SOURCE

NSP uses high efficiency LED Emitter. SP, FL, and MWFL use high efficiency LED Chip on Board with optimized melanopic ratios.

TM30	CCT (Nominal)	CRI	Rf	Rg	MR	SDCM
	2700K	81	80	97	2	2
	3000K	82	82	97	2	2
	3500K	82	81	97	2	2
	4000K	82	81	97	2	2
	5000K	84	81	97	2	2

Ra90 available upon request

OPTIC

Optical system is dependent on beam angle. NSP / SP / FL versions comprised with methacrylate lenses. MWFL version comprised of precision optics with convex reflective anodized aluminum facets.

Beam	NSP 5°	SP 16°	FL 30°	MWFL 48°
Delivered Lumens	3000K 162Lm	1,342Lm	1,403Lm	1,672Lm
	4000K 175Lm	1,418Lm	1,415Lm	1,685Lm

For 2700K lumen values use multiplier of 0.96 from 3000K. For 3500K lumen values use multiplier of 1.01 from 3000K. For 5000K lumen values use multiplier of 1.01 from 4000K.

Efficacy	112lm/W max. Refer to photometric graphs for specific values.
Lifetime	L80/B10 60,000hrs at max TA +25°C
Photobiological Classification	Low risk safety RG1

DART ROUND SMALL REMOTE

ORDERING CODE



1 - PRODUCT CODE	2 - DRIVER	3 - FINISH	4 - WATTAGE	5 - OPTIC	6 - KELVIN	7 - OPTIONAL
DRS — DART ROUND SMALL	RP — Remote Power	FE — Ferrite Dark Grey HB — Heritage Brown BZ — Bronze WT — White BT — Black SG — Sandstone Grey RAL — Custom RAL	L1 [®] — 2W L2 [®] — 15W	NS — NSP 5° SP — SP 16° FL — FL 30° MF — MWFL 48°	27 — 2700K 30 — 3000K 35 — 3500K 40 — 4000K 50 — 5000K	MG [®] — Marine Grade
8 - POWER SUPPLY	9 - EXTERNAL OPTICAL ACCESSORIES	10 - INSTALLATION ACCESSORIES	11 - TREE INSTALLATION ACCESSORIES			
REQUIRED See Power Supply section for available options.	Blade of Light Linear Spread Lens See section for details Anti-glare Louver See section for details Asymmetric Snoot See section for details Symmetric Snoot See section for details Symmetric Super Snoot See section for details	Rotational Bracket See section for details Earth spike See section for details Back Plate See section for details	Tree Strap See section for details Fixture Bracket See section for details Connection Box See section for details Mesh Protective Wiring See section for details			

[®] Marine Grade is recommended for use in environments with occasional exposure to salt air, reclaimed water, fertilizers, chemical cleaners, or frequent pressure washing (steam) cleaning. Fixture housing complete with marine grade cataphoresis suitable for use in marine grade environments. Not to be in direct contact with salt or corrosive agents for extended periods of time.

[®] 2W available with NSP only.

[®] 15W available with SP, FL, and MWFL only.

DART ROUND SMALL REMOTE

8 - POWER SUPPLY (REQUIRED)

ENCLOSURE								
Part No.	Wattage	Control	Dim Range	Rating	In / Out Voltage	Certification	Dimensions (Enclosure)	Description
DMLE301242UD	30W	MLV / ELV / 0-10V / TRIAC	MLV <10% / ELV <10% / 0-10V <5%	NEMA3R	120-277V / 24V	UL Class 2	4.47" X 6.79" X 1.38"	EMCOD MLE-UD electronic driver with wiring compartment.
DELV30124DJBX	30W	0-10V	1%	IP65	120-277V / 24V	UL Class 2	12.1" X 2.4" X 1.4"	Magnitude SOLIDrive electronic driver with built in junction box.
DMLE601242UD	60W	MLV / ELV / 0-10V / TRIAC	MLV <10% / ELV <10% / 0-10V <5%	NEMA3R	120-277V / 24V	UL Class 2	4.47" X 6.79" X 1.38"	EMCOD MLE-UD electronic driver with wiring compartment.
DELV60124DJBX	60W	0-10V	1%	IP65	120-277V / 24V	UL Class 2	12.1" X 2.4" X 1.4"	Magnitude SOLIDrive electronic driver with built in junction box.
DMLE961242UD	96W	MLV / ELV / 0-10V / TRIAC	MLV <10% / ELV <10% / 0-10V <5%	NEMA3R	120-277V / 24V	UL Class 2	5.16" X 7.73" X 1.54"	EMCOD MLE-UD electronic driver with wiring compartment.
DELV96124DJBX	96W	0-10V	1%	IP65	120-277V / 24V	UL Class 2	12.1" X 2.4" X 1.4"	Magnitude SOLIDrive electronic driver with built in junction box.
DMLE1922242UD	2X96W	MLV / ELV / 0-10V / TRIAC	MLV <10% / ELV <10% / 0-10V <5%	NEMA3R	120-277V / 24V	UL Class 2	5.04" X 10.94" X 1.81"	EMCOD MLE-UD electronic driver with wiring compartment.
DMLE2882242UD	3X96W	MLV / ELV / 0-10V / TRIAC	MLV <10% / ELV <10% / 0-10V <5%	NEMA3R	120-277V / 24V	UL Class 2	5.04" X 10.94" X 1.81"	Magnitude SOLIDrive electronic driver with built in junction box.

STANDALONE								
Part No.	Wattage	Control	Dim Range	Rating	In / Out Voltage	Certification	Dimensions (Standalone)	Description
DELV30124D	30W	0-10V	1%	IP65	120-277V / 24V	UR Class 2	7.5" X 2.4" X 1.4"	Magnitude SOLIDrive electronic standalone driver. UL listed enclosure provided by others.
DELV60124D	60W	0-10V	1%	IP65	120-277V / 24V	UR Class 2	7.5" X 2.4" X 1.4"	Magnitude SOLIDrive electronic standalone driver. UL listed enclosure provided by others.
DELV96124D	96W	0-10V	1%	IP65	120-277V / 24V	UR Class 2	7.5" X 2.4" X 1.4"	Magnitude SOLIDrive electronic standalone driver. UL listed enclosure provided by others.

MAX FIXTURES PER DRIVER

Fixture Wattage	Driver Wattage				
	30W	60W	96W	2X96W	3X96W
	2W	12	24	38	38+38
15W	1	3	5	5+5	5+5+5

MAX CABLE DISTANCE

Fixture Wattage	No. Fixtures	Load	18 AWG	16 AWG	14 AWG	12 AWG
2W	1-4	≤16W	72ft	115ft	180ft	290ft
	5-8	≤32W	42ft	67ft	106ft	165ft
	9-12	≤48W	28ft	44ft	70ft	112ft
	13-16	≤54W	20ft	33ft	52ft	84ft
	17-20	≤80W	16ft	26ft	41ft	66ft
15W	1	≤16W	72ft	115ft	180ft	290ft
	2	≤32W	42ft	67ft	106ft	165ft
	3	≤48W	28ft	44ft	70ft	112ft
	4	≤54W	20ft	33ft	52ft	84ft
	5	≤80W	16ft	26ft	41ft	66ft

*Voltage drop calculations are based on 3% max drop to last fixture in run for load and distances below

DART ROUND SMALL REMOTE

9 - EXTERNAL OPTICAL ACCESSORIES (OPTIONAL)

MAXIMUM OF TWO ACCESSORIES PER FIXTURE.

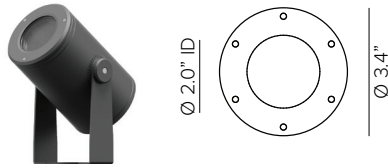

Blade Light Linear Spread Lens. PMMA holographic filter.

Part No. **1E4002 (*)**

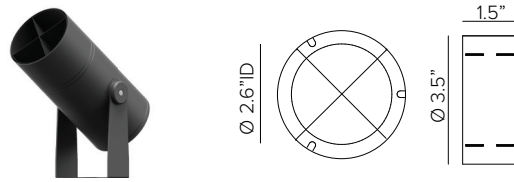

Anti glare louver with internal baffles for glare control. Powder coat stainless steel. Cutoff 103°. **Not compatible with 1E4003, 1E4004 or 1E4057.**

Part No. **1E4005 (*)**

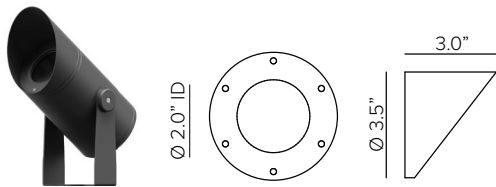

Asymmetric snoot. Powder coated stainless steel. Cutoff 53°. **Not compatible with 1E4004, 1E4005 or 1E4057.**

Part No. **1E4003 (*)**

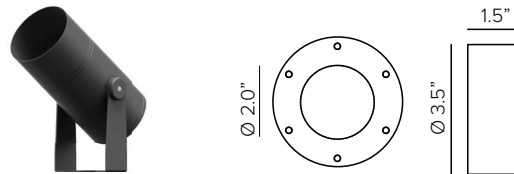

Symmetric snoot. Powder coated stainless steel. Cutoff 109°. **Not compatible with 1E4003, 1E4005 or 1E4057.**

Part No. **1E4004 (*)**

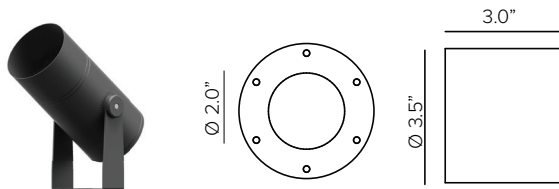

Symmetric super snoot. Powder coated stainless steel. Cutoff 53°. **Not compatible with 1E4003, 1E4004 or 1E4005.**

Part No. **1E4057 (*)**

- Ferrite Dark Grey (Default)
- Heritage Brown (HB)*
- Bronze (BZ)*
- White (WT)*
- Black (BT)*
- Sandstone Grey (SG)*

***Add suffix to end of number to identify finish (EX. 1E3015HB)**

DART ROUND SMALL REMOTE

10 - INSTALLATION ACCESSORIES (OPTIONAL)

MAXIMUM OF ONE ACCESSORY PER FIXTURE

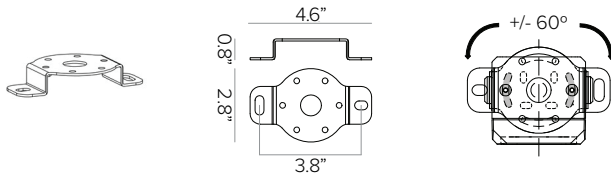

Rotational bracket for surface installation. Powder coated stainless steel.

Part No. **1E3015 (*)**

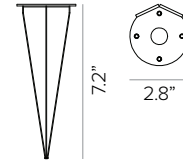

Earth spike. Powder coated stainless steel.

Part No. **1E3016 (*)**

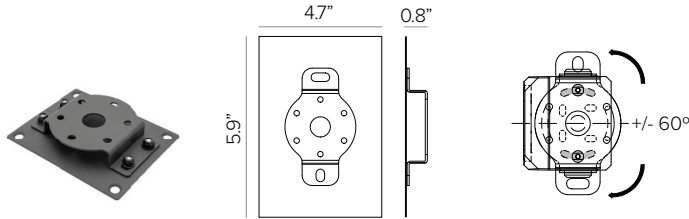

Back plate with rotational bracket for surface mount installation. Powder coated stainless steel with Neoprene black foam. Included with 1E3015 and factory attached Stainless Steel black oxide bolts and locking nuts.

Part No. **1US3015 (*)**

- Ferrite Dark Grey (*Default*)
- Heritage Brown (**HB**)*
- Bronze (**BZ**)*
- White (**WT**)*
- Black (**BT**)*
- Sandstone Grey (**SG**)*

***Add suffix to end of number to identify finish (EX. 1E3015HB)**

DART ROUND SMALL REMOTE

11 – TREE MOUNTING INSTALLATION (OPTIONAL)

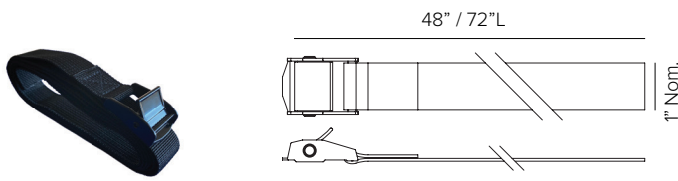

Tree strap. Durable marine grade polypropylene webbing flexible strap with stainless steel cam buckle. For single configuration, 1ea strap included. For double configuration, 2ea straps included. **(REQUIRED FOR TREE MOUNTING)**

Finish ● Black ● Coyote Brown ● Silver Grey ● Graphite Grey

SINGLE STRAP Maximum of 4ea fixture brackets per single strap.

Length 48"

Part No. **TTS01S48BK** **TTS01S48BR** **TTS01S48SG** **TTS01S48GG**

Length 72"

Part No. **TTS01S72BK** **TTS01S72BR** **TTS01S72SG** **TTS01S72GG**

DOUBLE STRAPS Maximum of 8 fixture brackets per double strap.

Length 48"

Part No. **TTS01D48BK** **TTS01D48BR** **TTS01D48SG** **TTS01D48GG**

Length 72"

Part No. **TTS01D72BK** **TTS01D72BR** **TTS01D72SG** **TTS01D72GG**

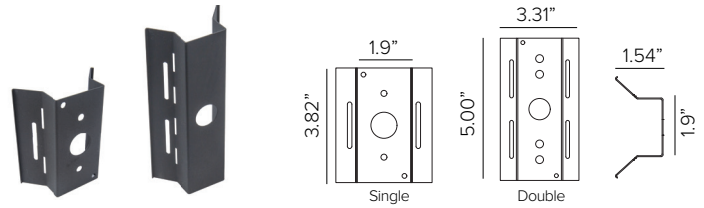

Fixture bracket comprised of powder coated stainless steel for use with tree strap. Single bracket to be used with single strap configuration. Double bracket to be used with double strap configuration. **(REQUIRED FOR TREE MOUNTING)**

Finish ● Black ● Bronze ● Sandstone Grey ● Ferrite Dark Grey

SINGLE BRACKET Maximum of 4ea fixture brackets per single strap.

Part No. **TTB01SBK** **TTB01SBZ** **TTB01SSG** **TTB01SFG**

DOUBLE BRACKET Maximum of 8 fixture brackets per double strap.

Part No. **TTB01DBK** **TTB01DBZ** **TTB01DSG** **TTB01DFG**

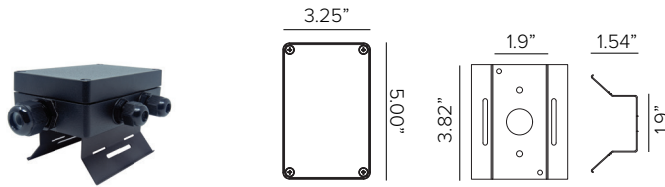

Connection box. Painted aluminum UL listed j-box with single input and 4ea max outputs for lateral cable exit. Provided with 1ea 1/2" cable gland and 4ea 3/8" cable gland, 3ea plugs provided along with mounting bracket, **tree strap sold separately**. Used to connect single 24V DC low voltage cable from remote driver to connection box. For single strap configuration, use 1ea connection box. For double strap configuration, use 2ea connection boxes. **(OPTIONAL)**

Finish ● Black ● Bronze ● Sandstone Grey ● Ferrite Dark Grey

Part No. **TTC02SBK** **TTC02SBZ** **TTC02SSG** **TTC02SFG**



Mesh wire protection cable sleeve, available per foot. Comprised of braided polyethylene terephthalate (PET) mono-filament webbing resistant to chemical degradation, UV radiation, and abrasion. **To be used in installations where multiple cables can be combined into a 'single' cable look and/or to conceal the cable to match the finish of the surface. (OPTIONAL)**

Finish ● Black ● Coyote Brown ● Silver Grey ● Graphite Grey

Part No. **TTMW01BK** **TTMW01BR** **TTMW01SG** **TTMW01GG**

TREE WIRING CONFIGURATION

Note: Suggested to adjust the strap every 6 months in order to prevent tree damage.

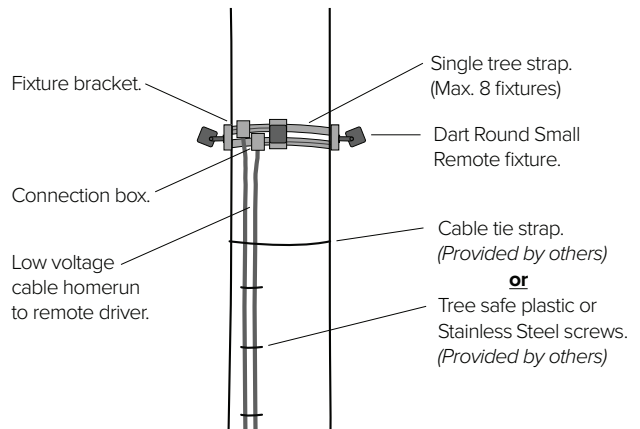
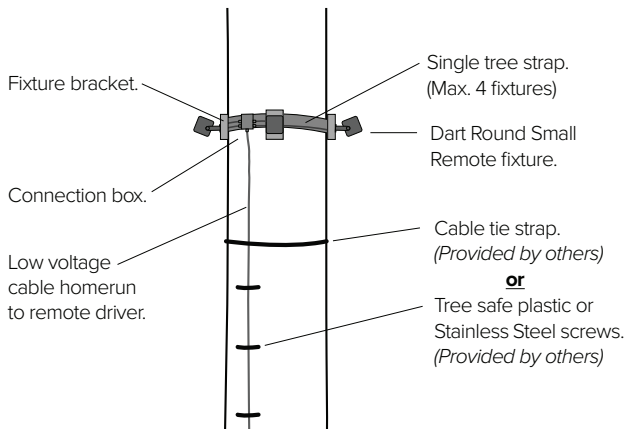

DART ROUND SMALL REMOTE

PHOTOMETRY

IES FILES WATTAGE AND EFFICIENCY CALCULATIONS BASED WITH SUPPLIED DRIVER

NARROW SPOT

	3000K	H(m)	D(m)	Emax(lx)		
	Ra80		5°			
	Fixture Power	2W	1	0.09	10538	
	Source Flux	230lm	2	0.18	2635	
	Fixture Flux	162lm	3	0.27	1171	
	Efficacy	77lm/W	4	0.36	659	
	TS1657	Imax=45818cd/klm	Imax	10538cd	5	0.45

	4000K	H(m)	D(m)	Emax(lx)		
	Ra80		5°			
	Fixture Power	2W	1	0.09	11363	
	Source Flux	248lm	2	0.18	2841	
	Fixture Flux	175lm	3	0.27	1263	
	Efficacy	83lm/W	4	0.36	710	
	TS1657	Imax=45818cd/klm	Imax	11363cd	5	0.45

SPOT

	3000K	H(m)	D(m)	Emax(lx)		
	Ra80		16°			
	Fixture Power	15W	1	0.28	13957	
	Source Flux	1928lm	2	0.56	3489	
	Fixture Flux	1342lm	3	0.84	1551	
	Efficacy	91lm/W	4	1.12	872	
	TS1658	Imax=7239cd/klm	Imax	13957cd	5	1.39

	4000K	H(m)	D(m)	Emax(lx)		
	Ra80		16°			
	Fixture Power	15W	1	0.28	14753	
	Source Flux	2038lm	2	0.56	3688	
	Fixture Flux	1418lm	3	0.84	1639	
	Efficacy	96lm/W	4	1.12	922	
	TS1658	Imax=7239cd/klm	Imax	14753cd	5	1.39

FLOOD

	3000K	H(m)	D(m)	Emax(lx)		
	Ra80		30°			
	Fixture Power	14W	1	0.53	4710	
	Source Flux	2184lm	2	1.06	1178	
	Fixture Flux	1403lm	3	1.59	523	
	Efficacy	103lm/W	4	2.12	294	
	TS1659	Imax=2157cd/klm	Imax	4710cd	5	2.66

	4000K	H(m)	D(m)	Emax(lx)		
	Ra80		30°			
	Fixture Power	14W	1	0.53	4749	
	Source Flux	2202lm	2	1.06	1187	
	Fixture Flux	1415lm	3	1.59	528	
	Efficacy	104lm/W	4	2.12	297	
	TS1659	Imax=2157cd/klm	Imax	4749cd	5	2.66

MEDIUM WIDE FLOOD

	3000K	H(m)	D(m)	Emax(lx)		
	Ra80		48°			
	Fixture Power	14W	1	0.89	2766	
	Source Flux	2192lm	2	1.77	691	
	Fixture Flux	1672lm	3	2.66	307	
	Efficacy	123lm/W	4	3.55	173	
	TS1660	Imax=1299cd/klm	Imax	2847cd	5	4.44

	4000K	H(m)	D(m)	Emax(lx)		
	Ra80		48°			
	Fixture Power	14W	1	0.89	2789	
	Source Flux	2210lm	2	1.77	697	
	Fixture Flux	1685lm	3	2.66	310	
	Efficacy	124lm/W	4	3.55	174	
	TS1660	Imax=1299cd/klm	Imax	2870cd	5	4.44