

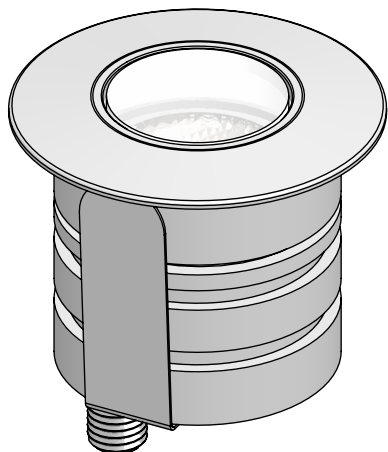

JUPITER DOWNLIGHT JUDR-

PROFESSIONAL LED DOWNLIGHT



IP68^B
IP69K



IK 10
24V DC

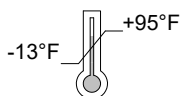

If in doubt about the symbols please refer to catalog or website

JUPITER MINI DOWNLIGHT JMDR-

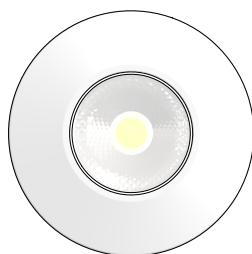

WARNING

To ensure a maximum efficient use of the product, read the instructions before proceeding installment.

- This fixture must be installed by a licensed and qualified electrician. The installer must comply with NEC and local building codes when installing the fixture.
- Electrical current can cause painful shock, serious injury, or even death. Make sure you turn off the power supply, ground fixture(s), and make sure all electrical connections are correct and secured tightly.
- For use in IP67 installations.
- Keep the label of the original packaging if any eventual future claims are needed.

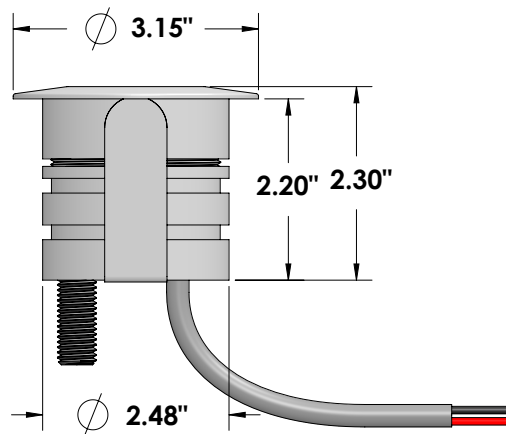
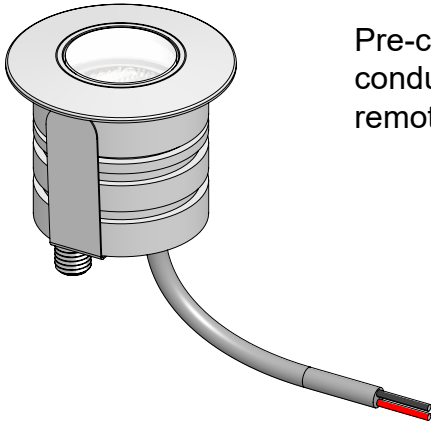

Table of Contents

Packaging Contents	Pg.2
Fixture Installation Instructions	Pg.3
Power Supply	Pg.4
Fixture Wiring Layout	Pg.5
Maintenance / Support	Pg.6

Packaging Contents



Pre-cabled with 2ft direct burial 18ga 2 conductor cable for connection to remote power supply.

JUPITER DOWNLIGHT

Finish

- Brushed Natural
- Bronze PVD*
- Black PVD*

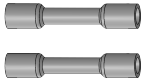

Heat-shrink Solder Seal
Waterproof connectors
2 ea.

4" Heat-shrink tubing
1 ea.



4"x 4"x 4" Box @1.1lbs

Mounting Dimensions

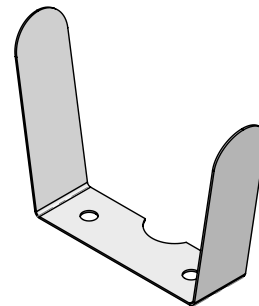
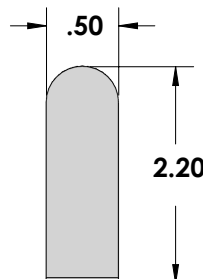
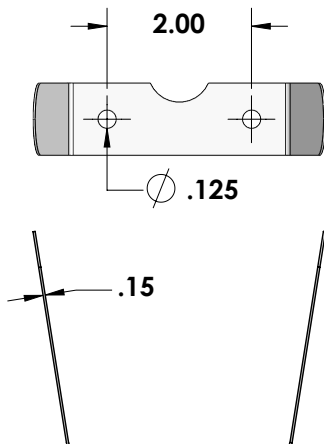

Fixture Installation Instructions

Ceiling Wood / Drywall or Other

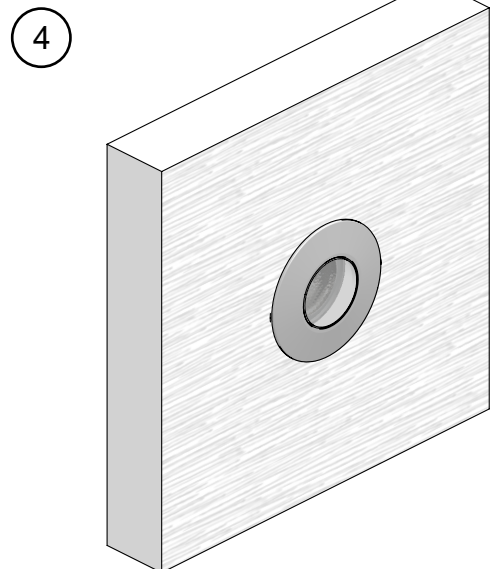
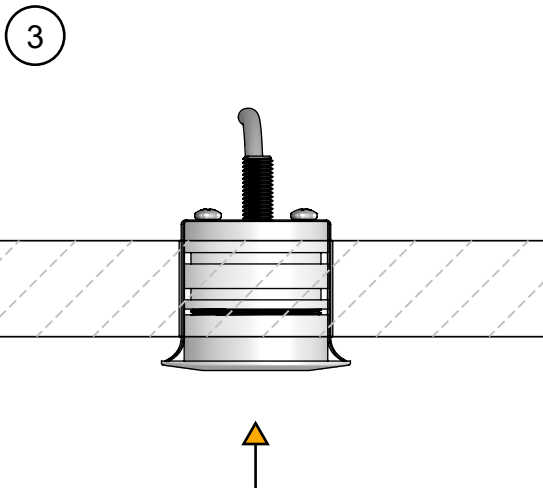
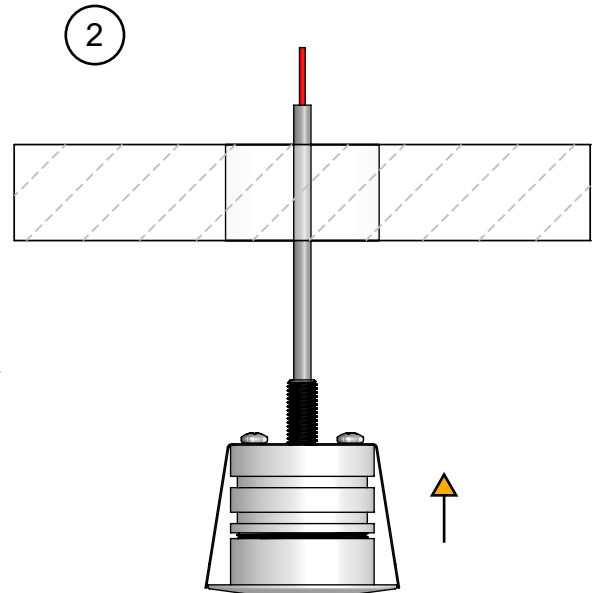
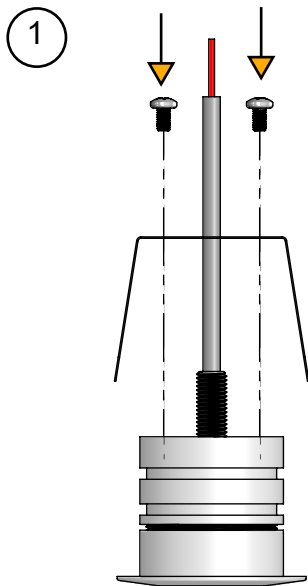
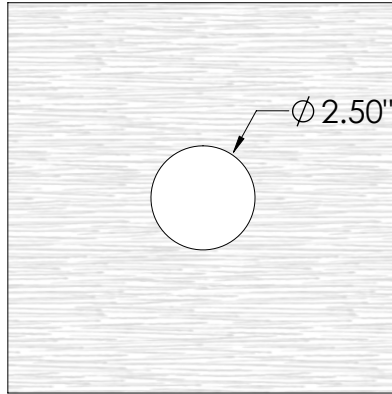

Power Supply (Required)

ENCLOSURE								
Part No.	Wattage	Control	Dim Range	Rating	In / Out Voltage	Certification	Dimensions (Enclosure)	Description
DMLE301242UD	30W	MLV / ELV / 0-10V / TRIAC	10%	NEMA3R	120-277V / 24V	UL Class 2	4.47" X 6.79" X 1.38"	EMCOD MLE-UD electronic driver with wiring compartment.
DELV30124DJBX	30W	0-10V	0.1%	IP65	120-277V / 24V	UL Class 2	12.1" X 2.4" X 1.4"	Magnitude SOLIDrive electronic driver with built in junction box.
DMLE601242UD	60W	MLV / ELV / 0-10V / TRIAC	10%	NEMA3R	120-277V / 24V	UL Class 2	4.47" X 6.79" X 1.38"	EMCOD MLE-UD electronic driver with wiring compartment.
DELV60124DJBX	60W	0-10V	0.1%	IP65	120-277V / 24V	UL Class 2	12.1" X 2.4" X 1.4"	Magnitude SOLIDrive electronic driver with built in junction box.
DMLE961242UD	96W	MLV / ELV / 0-10V / TRIAC	10%	NEMA3R	120-277V / 24V	UL Class 2	5.16" X 7.73" X 1.54"	EMCOD MLE-UD electronic driver with wiring compartment.
DELV96124DJBX	96W	0-10V	0.1%	IP65	120-277V / 24V	UL Class 2	12.1" X 2.4" X 1.4"	Magnitude SOLIDrive electronic driver with built in junction box.
DMLE1922242UD	2X96W	MLV / ELV / 0-10V / TRIAC	10%	NEMA3R	120-277V / 24V	UL Class 2	5.04" X 10.94" X 1.81"	EMCOD MLE-UD electronic driver with wiring compartment.
DMLE2882242UD	3X96W	MLV / ELV / 0-10V / TRIAC	10%	NEMA3R	120-277V / 24V	UL Class 2	5.04" X 10.94" X 1.81"	EMCOD MLE-UD electronic driver with wiring compartment.

STANDALONE								
Part No.	Wattage	Control	Dim Range	Rating	In / Out Voltage	Certification	Dimensions (Standalone)	Description
DELV30124D	30W	0-10V	0.1%	IP65	120-277V / 24V	UR Class 2	7.5" X 2.4" X 1.4"	Magnitude SOLIDrive electronic standalone driver. UL listed enclosure provided by others.
DELV60124D	60W	0-10V	0.1%	IP65	120-277V / 24V	UR Class 2	7.5" X 2.4" X 1.4"	Magnitude SOLIDrive electronic standalone driver. UL listed enclosure provided by others.
DELV96124D	96W	0-10V	0.1%	IP65	120-277V / 24V	UR Class 2	7.5" X 2.4" X 1.4"	Magnitude SOLIDrive electronic standalone driver. UL listed enclosure provided by others.

MAX FIXTURES PER DRIVER						
Fixture Wattage	Driver Wattage					
	30W	60W	96W	2 x 96W	3 x 96W	
	7W	3	6	10	10+10	10+10+10

MAX CABLE DISTANCE						
Fixture Wattage	No. Fixtures	Load	18 AWG	16 AWG	14 AWG	12 AWG
7W	3	≤21W	55ft	85ft	140ft	220ft
	6	≤42W	31ft	50ft	80ft	125ft
	10	≤70W	19ft	30ft	48ft	75ft

*Voltage drop calculations are based on 3% max drop to last fixture in run for load and distances below

Fixture Wiring Layout

Installer will wire the Jupiter Downlight fixture(s) with the daisy chain connection as shown in the diagram below. Be sure that the wiring is done by a qualified electrician that complies with NEC and local building code when installing this product. Provided cable for the fixtures must be UL listed, direct burial, and weatherproof and properly sized based on the amount of fixtures, lengths of wiring, and compliance of NEC regulations.

Use proper UL listed waterproof wire connectors depending on conductor size.

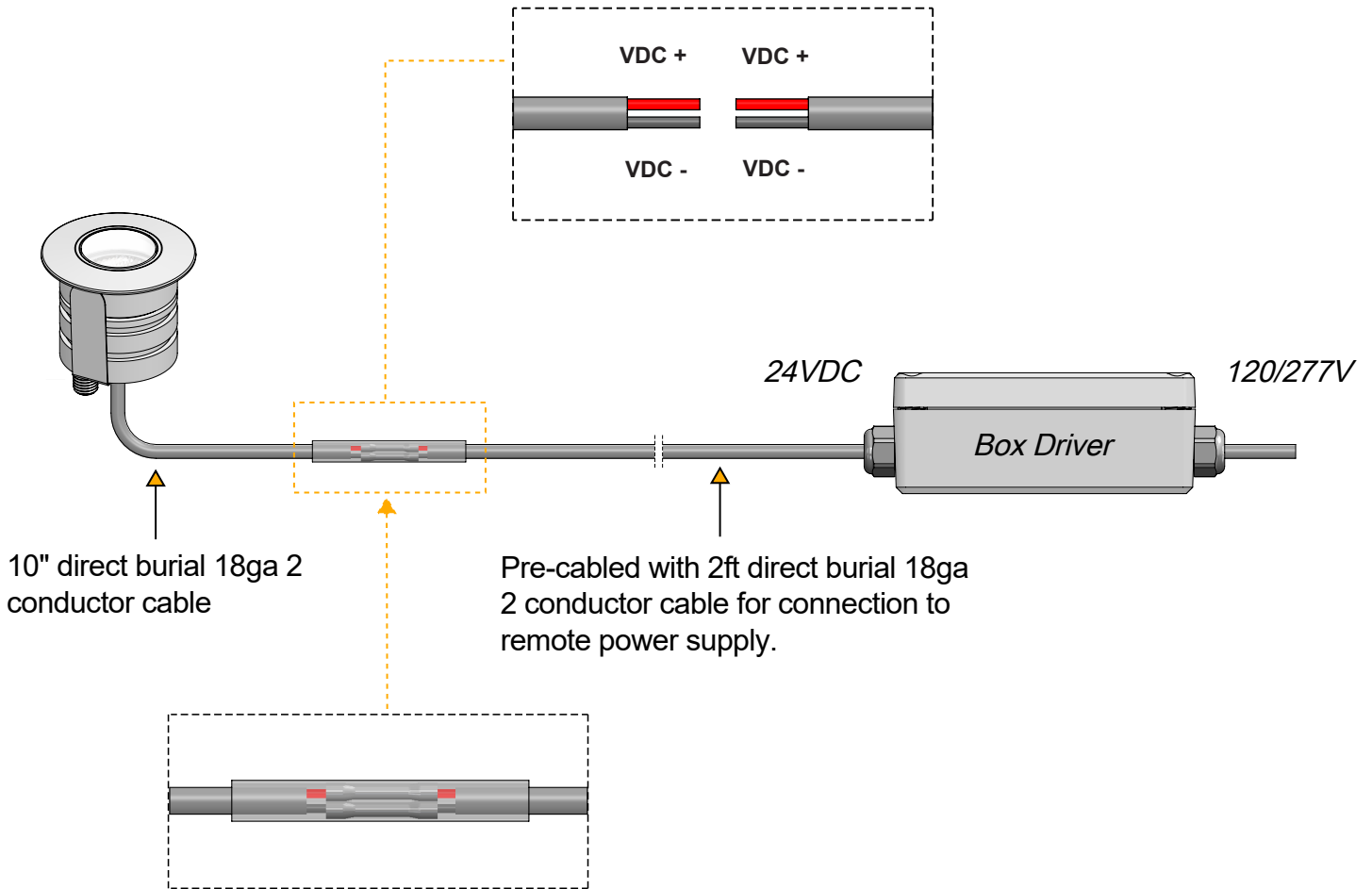

Waterproof Heat-shrink solder seal connectors and Heat-shrink tube (included with fixture)

Maintenance

This fixture was designed and manufactured for a durable, long lasting use with minimum care. To ensure the maximum lifespan of this product, we encourage our customer to provide a quality visual inspection of the fixture and installation accessories every six months.

If there are any visible sign of issues (i.e moisture or dust) during the inspection, please clean any of the dust or moisture with a soft cloth and check to make sure that any of the fixtures are still operating normally. If there are any issues regarding the fixture please contact us as we will assist the situation at hand.

Support

Any questions, problems, or comments you have please feel free to contact our Customer Service department during our business hours Monday-Friday

8am-5pm via: Email: usaorders@targetti.com

Phone: (714) 513-1991

Visit our website: <http://www.targettiusa.com>